

EU-TYPE EXAMINATION CERTIFICATE

Issued by Liftinstituut B.V.
identification number Notified Body 0400,
commissioned by Decree no. 2016-0000038870

Certificate no. : NL12-400-1002-169-05 Revision no.: 1

Description of the product : Safety gear as braking part of Unintended Car Movement Protection (UCMP)

Trademark, type : Schlosser, EB 75 GS

Name and address of the manufacturer : G. Schlosser Aufzugtechnologie GmbH
Felix-Wankel-Strasse 4
D-85221 Dachau
Germany

Name and address of the certificate holder : G. Schlosser Aufzugtechnologie GmbH
Felix-Wankel-Strasse 4
D-85221 Dachau
Germany

Certificate issued on the following requirements : Lifts Directive 2014/33/EU

Certificate based on the following standard : EN 81-20:2014, EN 81-50:2014
Parts of:

Test laboratory : None

Date and number of the laboratory report : None

Date of EU-type examination : April – June 2012, May, 2017

Additional document with this certificate : Report belonging to the EU-type examination certificate no.: NL12-400-1002-169-05 Rev.1

Additional remarks : None

Conclusion : The safety component meets the requirements of the Lifts Directive 2014/33/EU taking into account any additional remarks mentioned above.

Amsterdam

Date : 30-05-2017

Valid until : 30-05-2022

ing. J.L. van Vliet
Managing Director
Certification decision by

Report EU-type examination

Report belonging to EU-type examination certificate no. : NL12-400-1002-169-05
Date of issue of original certificate : 24-07-2012
Concerns : Safety component
No. and date of revision : 1. 30-05-2017
Requirements : Lifts Directive 2014/33/EU
Standard(s):
EN 81-20:2014, EN 81-50:2014
under exclusion of articles -
Project no. : P170076

1. General specifications

Name and address manufacturer : G. Schlosser Aufzugtechnologie GmbH
Felix-Wankel-Strasse 4
D-85221 Dachau
Germany
Description of safety component : Safety gear as braking part of Unintended
Car Movement Protection (UCMP)
Type : EB 75 GS
Laboratory : -
Address of examined lift : -
Data of examination : April 2012, April 2017
Examination performed by : A. van den Burg

2. Description safety component

The EB 75 GS is an eccentric type progressive safety gear intended and already certified for use as a safety gear in downward direction and as an ascending car overspeed protection in upward direction.

This certificate is an addition that allows the component to be also used as the braking element of an uncontrolled car movement protection as described in EN 81-20:2014.

The safety gears must be activated by a suitable governor that shall be pre triggered when the car doors are open, this governor shall be certified as part of an unintended car movement protection.

Alternatively, another means that is certified to detect uncontrolled car movement in combination with a suitable safety gear activation mechanism can be used.

The safety gear may be used in up or down direction, depending on the mounting orientation.

The user shall verify by calculation (or testing) that the lift is stopped within the allowable limits as specified in EN 81-20:2014 art. 5.6.7.5.

The calculation shall take into account all delays that increase the stopping distance. Delays to be considered for calculation of the stopping distance:

- Eventual delay of the triggering.
- Delay of the activation mechanism.
- Delay of the safety gear before the full braking force is reached (77 mm).
- The additional braking distance of the safety gear under worst case loading conditions from maximum possible triggering speed when it is not already pre triggered at standstill.

For application in down direction, all application conditions and limits as mentioned in the certificate EU-SG 289 shall be respected.

For application in upward direction, all application conditions and limits as mentioned in the certificate EU-SG 289 shall be respected.

The maximum delay of the safety gear from start of activation until full brake force is reached can be expressed in a rotation angle of 90° of the eccentric which is equivalent to an additional travel of 77 mm (see Annex 1A).

The type of mechanism determines the additional travel of the activation mechanism.

In case a standard Schlosser activation mechanism is used, the delay of the safety gear including mechanism in upward activation direction is found to be 105 or 110 mm at maximum. This value is found when the governor rope is mounted to the outer hole of the activation lever, in case the governor is mounted to the middle or inner hole, the activation distance is reduced (see Annex 1B for the combination with KB55S and Annex 1C for the combination with KB55SS).

3. Examinations and tests

The examination covered a check whether compliance with the Lift Directive 2014/33/EU is met, if possible based on the harmonized product standards EN 81-20:2014 and EN 81-50:2014.

Issues not covered by or not complying these Standards are directly related to the above mentioned essential requirements based on the risk assessment, where applicable with the aid of harmonized A-and B-standards.

The examination included:

- examination of the technical file consisting of:
 - all relevant information of the component,
 - technical drawings,
 - service manual.
- examination of the representative model in order to establish conformity with the technical file.
- tests and inspections to check compliance with the essential demands of the Lifts Directive, special attention is given to the activation delay and to the fact that the safety gear shall also work at low activation speed.

4. Results

After the examination the safety gear and the technical file were found in accordance with the requirements.

The functional tests passed without remarks and the safety gears activated within the defined distance, also at very low activation speed.

A description of the tests performed is given in "Test report type-examination NL12-400-1002-169-01/05" issued by the Liftinstituut on July 24th 2012.

5. Conditions

On the EU-type examination certificate the following conditions apply:

- An additional calculation shall be done to check whether the stopping distance of the car is within the limits as required by EN 81-20:2014 art. 5.6.7.5. For each lift model the calculations shall be checked and approved. When the braking force "F" of the safety gear is not directly provided, for calculations it can be taken as 16x the adjusted mass, $F=16(P+Q)$, Car mass "P" and nominal load "Q" in [kg], "F" in [N].
- For application in down direction, all application conditions and limits as mentioned in the certificate EU-SG 289 shall be respected.
- For application in upward direction, all application conditions and limits as mentioned in the certificate EU-SG 289 shall be respected.

6. Conclusions

Based upon the results of the EU-type examination Liftinstituut B.V. issues an EU-type examination certificate.

The EU-type examination certificate is only valid for products which are in conformity with the same specifications as the type certified product. The certificate is issued based on the requirements that are valid at the date of issue. In case of changes of the product specifications, changes in the requirements or changes in the state of the art the certificate holder shall request Liftinstituut B.V. to reconsider the validity of the certificate.

7. CE marking and EU Declaration of conformity

Every safety component that is placed on the market in complete conformity with the examined type must be provided with a CE marking according to article 18 of the Lift directive 2014/33/EU under consideration that conformity with eventually other applicable Directives is proven. Also every safety component must be accompanied by an EU declaration of conformity according to annex II of the Directive in which the name, address and Notified Body identification number of Liftinstituut B.V. must be included as well as the number of the EU-type examination certificate.

An EU type-certified safety component shall be random checked e.g. according to annex IX of the Lift directive 2014/33/EU before these safety components may be CE-marked and may be placed on the market. For further information see regulation 2.0.1 'Regulations for product certification' on www.liftinstituut.com.

Prepared by:



A. van den Burg
Productspecialist Certificatie
Liftinstituut B.V.

Certification decision by:



Annexes

Annex 1A : Activation distance of EB 75 GS safety gear (maximum distance travelled between start of activation until full force in both up direction and down direction if mounted upside down)

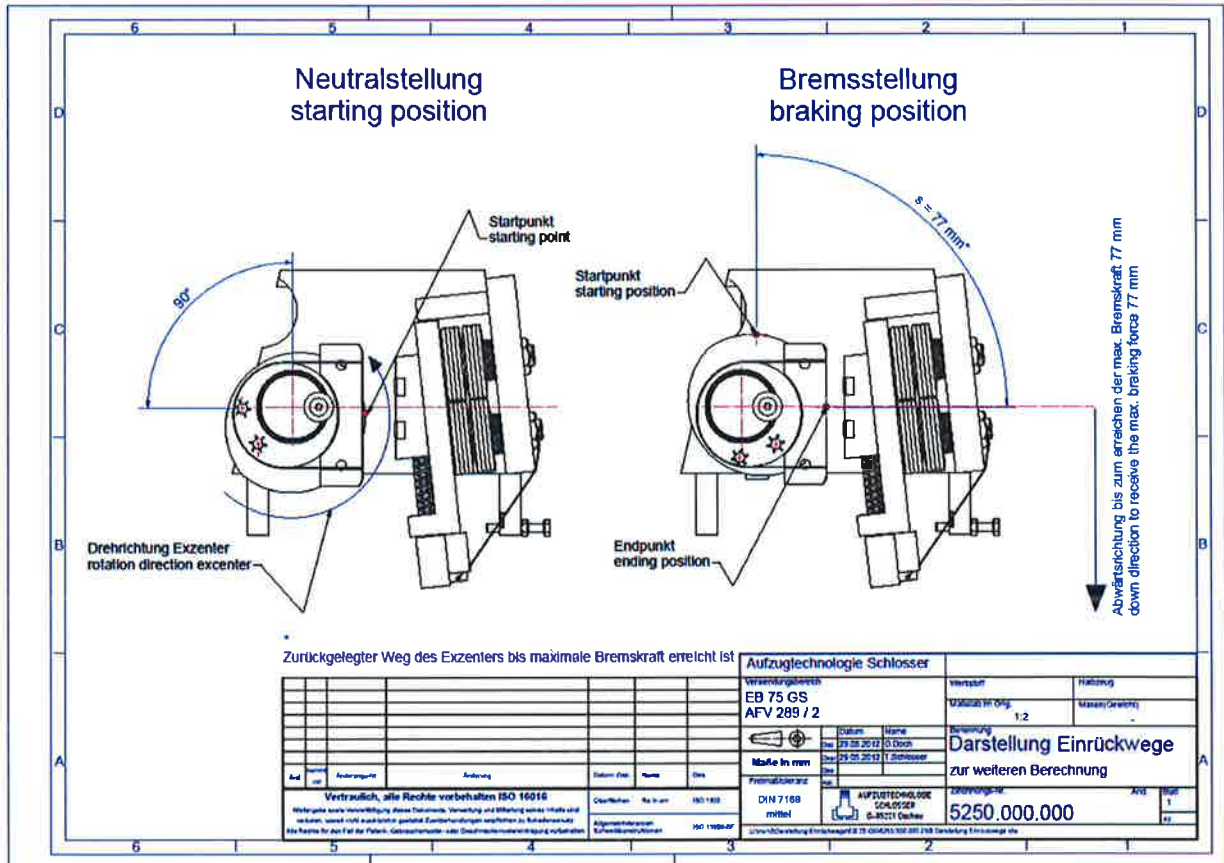

Annex 1B : Activation distance of EB 75 GS safety gear in upward direction with Schlosser activation mechanism applied (combination with KB55S).

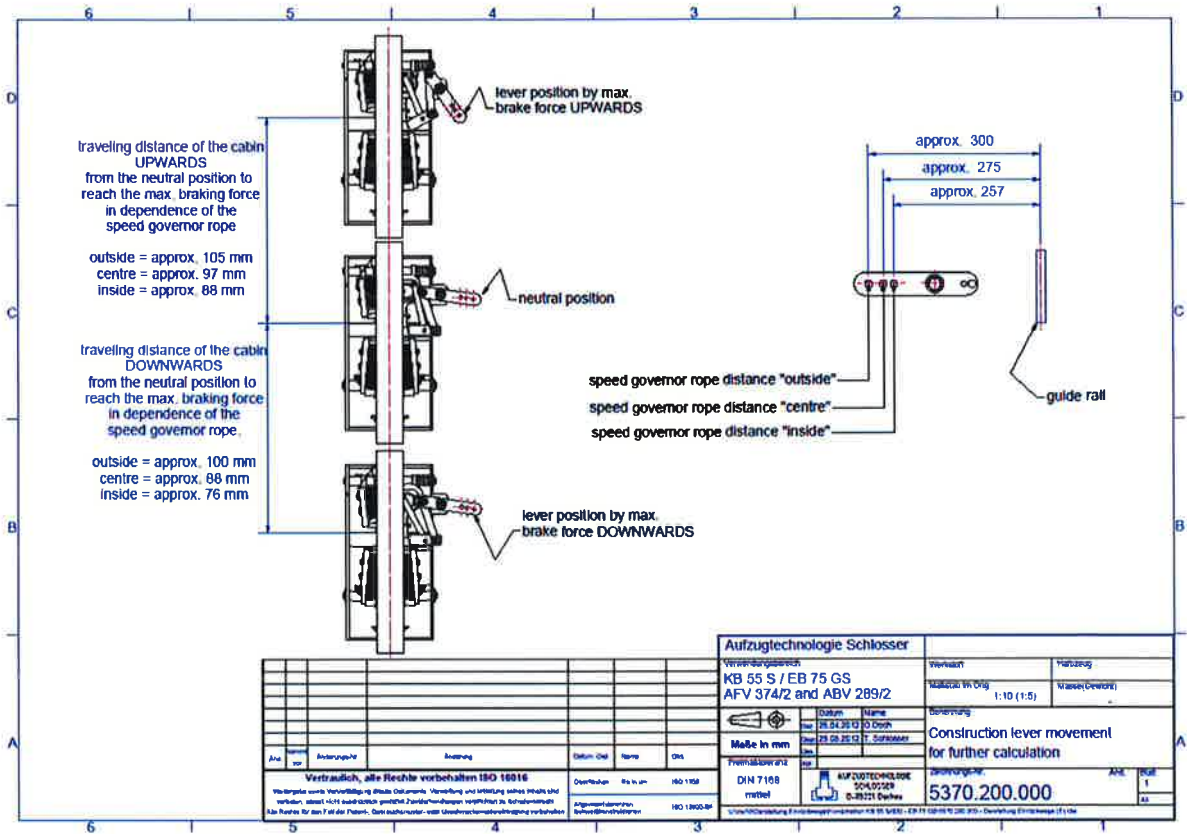

Annex 1C : Activation distance of EB 75 GS safety gear in upward direction with Schlosser activation mechanism applied (combination with KB55SS).

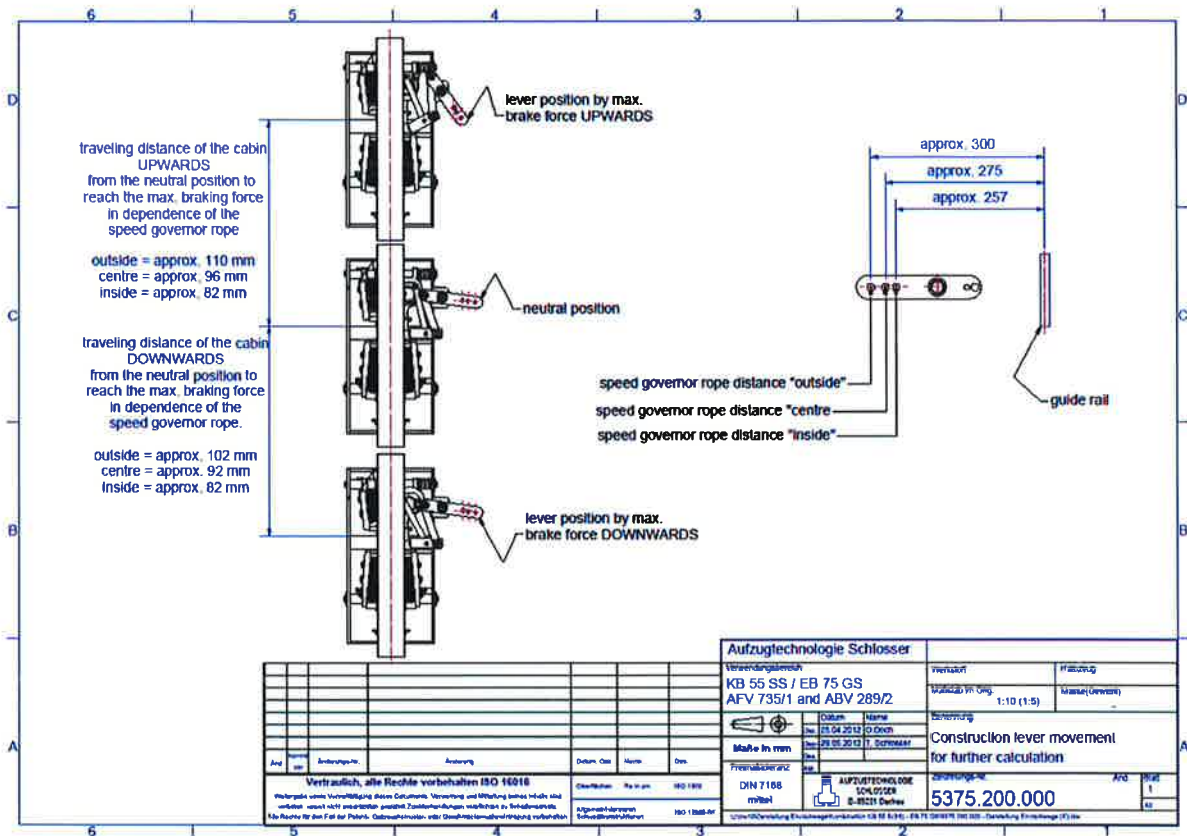

Annex 2 Documents of the Technical File which were subject of the examination

title	document number	date
Montage-Betriebs-Wartungsanleitung	-	15-02-2011

Annex 3. Reviewed deviations from the standards

EN xx-x par.	Requirement	Accepted design
None		

Annex 4 Revision overview

REVISIONS OF THE CERTIFICATE AND REPORT

Rev.:	Date	Summary of revision
-	24-07-2012	Original
1	30-05-2017	Update to EU-Type examination certificate 2014/33/EU, EN 81-20 and EN 81-50