



Industrie Service

EU-TYPE EXAMINATION CERTIFICATE

According to Annex IV, Part A of 2014/33/EU Directive

Certificate No.: EU-SG 490

Certification Body of the Notified Body: TÜV SÜD Industrie Service GmbH
Westendstr. 199
80686 Munich – Germany
Identification No. 0036

Certificate Holder: G. Schlosser Aufzugtechnologie GmbH
Felix-Wankel-Strasse 4
85221 Dachau – Germany

Manufacturer of the Test Sample: G. Schlosser Aufzugtechnologie GmbH
Felix-Wankel-Strasse 4
85221 Dachau – Germany
(Manufacturer of Serial Production - see Enclosure)

Product: Progressive safety gear, braking device as part of the protection device against overspeed for the car moving in upwards direction and braking element against unintended car movement

Type: EB 75 KD

Directive: 2014/33/EU

Reference Standards: EN 81-20:2014
EN 81-50:2014
EN 81-1:1998+A3:2009
EN 81-2:1998+A3:2009

Test report: EU-SG 490 of 2016-07-25

Outcome: The safety component conforms to the essential health and safety requirements of the mentioned Directive as long as the requirements of the annex of this certificate are kept.

Date of Issue: 2016-07-25

Achim Janocha
Certification Body "lifts and cranes"



**Annex to the EU-Type-Examination Certificate
No. EU-SG 490 of 2016-07-25**



Industrie Service

1 Scope of application

1.1 Generally

Following application possibilities refer to a brand new pair of safety gear depending on manufacture and condition of the guide rail running surface and maximum rated and tripping speed. The safety component can fulfil separately and in combination three security features according 1.2, 1.3 and 1.4.

Guide rails to be used

Minimum running surface width 25 mm

Blade width 8 – 19 mm

Notes:

- * Mineral oils without additives (e.g. lubricating oils C according DIN 51517, part 1)
- ** Response distance: Defined as the maximum distance, that can be covered by the car between inoperative position of the safety gear and until the car lies against the guide rails (start of retraction)
- *** Retraction distance: Defined as the maximum distance that can be covered by a car with parallel build-up of the braking force until the safety gear has reached its final position (limit stop)

1.2 Using as a progressive safety gear (acting downwards) - permissible total mass of car and rated load depending on maximum rated and tripping speed

Manufacturing of running surface	Condition guide rail	Max. range of rated speed [m/s]	Max. tripping speed [m/s]	Total mass [kg] min. – max.
drawn	dry	1.73 – 1.88	2.16	1542 – 2405
		2.10 – 2.29	2.63	1542
	oiled*	1.73 – 1.88	2.16	1288 – 2686
		2.10 – 2.29	2.63	1288
machined	dry	1.73 – 1.88	2.16	1492 – 3008
		2.10 – 2.29	2.63	1492
	oiled*	1.73 – 1.88	2.16	1446 – 3196
		2.10 – 2.29	2.63	1446

For the intermediate values of the maximum tripping speed of 2,16 - 2,63 m/s the corresponding maximum total mass can be determined through linear interpolation in the range of 1542 - 2405, 2686 - 1288, 3008 - 1492 and 3196 - 1446 kg.

1.3 Using as a braking device - part of the protection device against overspeed for the car moving in upwards direction (acting upwards) - permissible brake forces

Manufacturing of running surface	Condition guide rail	Max. tripping speed [m/s]	Brake force [N] min. – max.
drawn	dry	2.16	8542 – 16004
		2.63	8542
	oiled*	2.16	8705 – 21547
		2.63	8705
machined	dry	2.16	10872 – 17751
		2.63	10872
	oiled*	2.16	11161 – 18702
		2.63	11161

Annex to the EU-Type-Examination Certificate No. EU-SG 490 of 2016-07-25



Industrie Service

For the intermediate values of the maximum tripping speed of 2,16 - 2,63 m/s the corresponding maximum brake force can be determined through linear interpolation in the range of 1542 - 2405, 2686 - 1288, 3008 - 1492 and 3196 - 1446 kg and the brake force 16004 - 8542, 21547 - 8705, 17751 - 10872 and 18702 - 11161 N.

- 1.4 Using as a braking element - part of the protection device against unintended car movement (acting upwards and downwards) - permissible brake forces, range of tripping speed and design features

Manufacturing of running surface	Condition guide rail	Effecting direction	Max. tripping speed [m/s]	Brake force [N] min. – max.
drawn / machined	dry or oiled*	downwards	2.10	20608 – 51136
		upwards	2.10	8542 – 21547

Assigned arrangement and design features

- Air gap in acc. w. assembly instructions
- Maximum total distance = response distance* + retraction distance**:
 - Upwards 145 mm
 - Downwards 110 mm

2 Terms and Conditions

- 2.1 Above mentioned safety component represents only a part at the protection device against over-speed for the car moving in upwards direction and unintended car movement. Only in combination with a detecting and triggering component in accordance with the standard (two separate components also possible), which must be subjected to an own type-examination, can the system created fulfil the requirements for a protection device.
- 2.2 The forces acting on the guide rails shall be safety absorbed.
- 2.3 Mass configuration of the lift installation with regard to the permissible total mass and braking forces to be construed in a way that comply with the valid values of deceleration according standard EN 81-20 based on safety function (e.g. deceleration of the empty car in up direction not more than $1g_n$).
- 2.4 The installer of the complete lift must create an examination instruction to fulfil the overall concept of the protection device, add it to the lift documentation and provide any necessary tools or measuring devices, which allow a safe examination (e. g. with closed landing doors).
- 2.5 The identification drawing No. 5350.600.000 including stamp dated 2016-07-25 shall be included to the EU type-examination for the identification and information of the general construction and operation and distinctness of the approved type.
- 2.6 The EU type-examination certificate may only be used in combination with the corresponding annex and enclosure (List of authorized manufacturer of the serial production). The enclosure will be updated immediately after any change by the certification holder.

3 Remarks

- 3.1 Due to the characteristics, the brake force for the progressive safety gear acting downwards and the brake force for the braking device acting upwards are permanently related to each other. They cannot be adjusted separately in principle. The permissible total mass stated in 1.2 thus also is permanently related to the permissible brake force as defined in 1.3 and 1.4.
- 3.2 Pursuant to the comment standard EN 81-50, the total mass determined for adjustment purposes may be 7.5 % higher or lower.

**Annex to the EU-Type-Examination Certificate
No. EU-SG 490 of 2016-07-25**



Industrie Service

- 3.3 The progressive safety gear can also be used to a counterweight in compliance with the permissible total mass according table 1.2 of this certificate till permissible tripping speed.
- 3.4 It can be assumed, that with regard to low tripping speeds (based on the associated test report) according item 1.4 the braking element (part of the protection device against unintended car movement) provides functionality itself.
- 3.5 Examination of compliance with other requirements according standard, reduction of braking forces due to wear-and-tear or alterations to the installation due to the installation's operation such as alterations to the running surfaces of the guide rails, are not part of this type-examination.
- 3.6 This EU type-examination certificate was issued according to the following standards:
- EN 81-1:1998 + A3:2009 (D), Annex F.3, F.7 and F.8
 - EN 81-2:1998 + A3:2009 (D), Annex F.3 und F.8
 - EN 81-20:2014 (D), part 5.6.2.1.1.2, part 5.6.6.11 and part 5.6.7.13
 - EN 81-50:2014 (D), part 5.3, 5.7 and 5.8

A revision of this EU type-examination certificate is inevitable in case of changes or additions of the above mentioned standards or of changes of state of the art.

**Enclosure to the EU Type-Examination Certificate
No. EU-SG 490 of 2016-07-25**



Industrie Service

Authorised Manufacturer of Serial Production – Production Sites (valid from: 2016-07-25):

Company G. Schlosser Aufzugtechnologie GmbH
Address Felix-Wankel-Strasse 4
85221 Dachau – Germany

- END OF DOCUMENT -

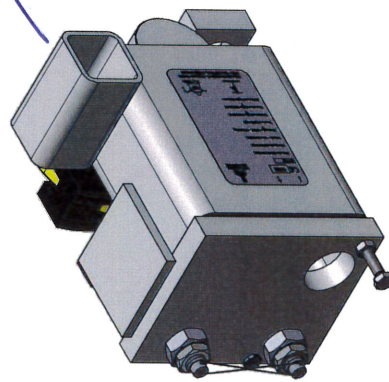
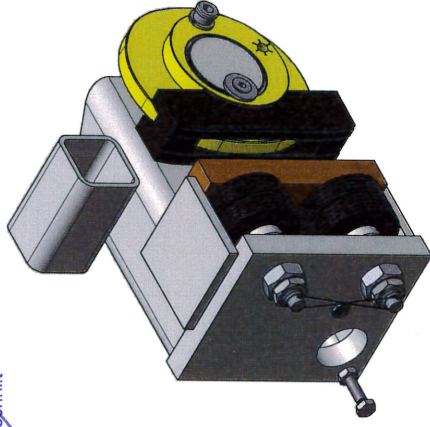
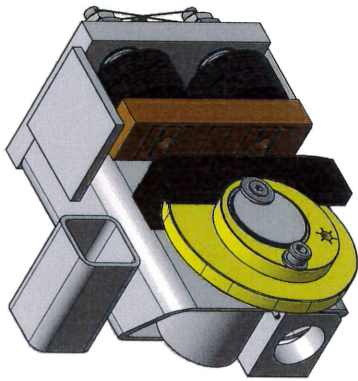
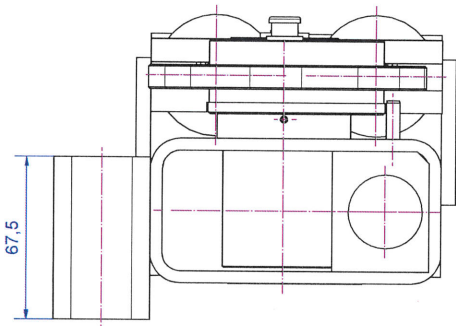
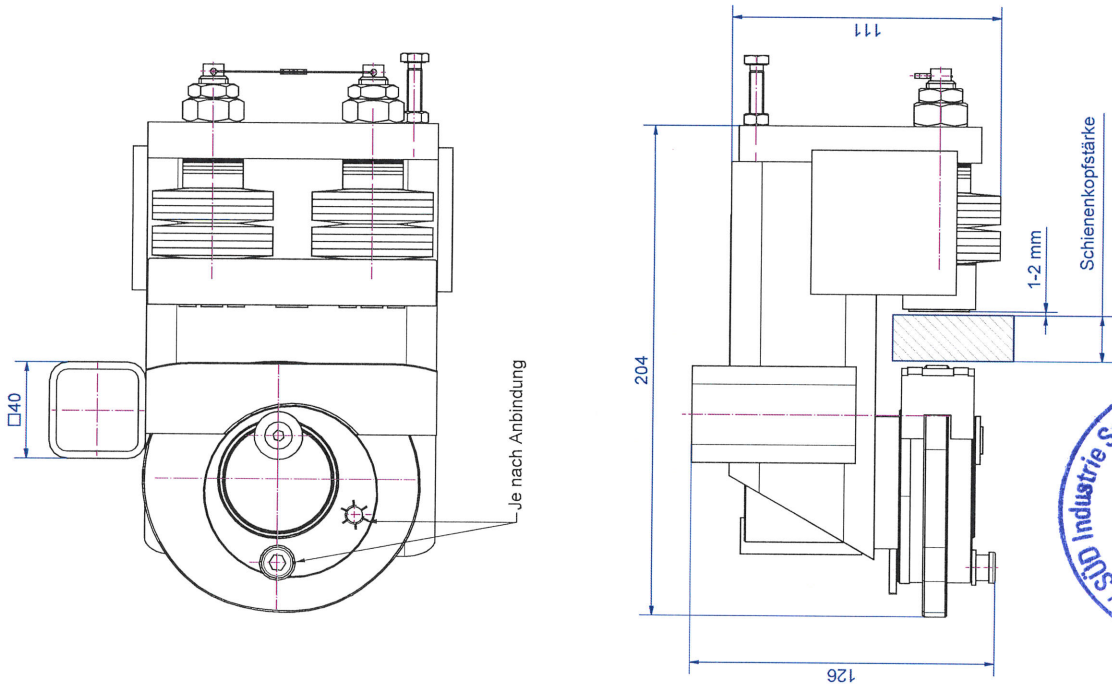

2 5. JULI 2016

GEPRÜFT / APPROVED
 TÜV SÜD Industrie Service GmbH
 Prüflaboratorium für Produkte der Fördertechnik
 Westendstraße 199
 80686 München
 Sachverständige(r) / Expert



Aufzugtechnologie Schlosser		Werkstoff	Halbzeug
Verwendungsbereich		Maßstab im Orig.	1:1,5 (1:2)
EU-SG 490		Benennung	Masse (Gewicht) 8,2 kg
Datum	Name	Zeichnungs-Nr.	
04.07.2016	Martinez	5340.0000.012	
Blatt	von	Blatt	
1	1	1	
Maße in mm		Dimension Drawing EB 75 KD	
Toleranz		Zuordnung:	
ISO 8015		5340.0000.012	
ISO 2768-mH		Blatt	
D-8221 Darbau		1	
JAMA BELFANGSTRASSE 75 90534G 0000 012 - EB 75 KD.dwg		AZ	
AUZÜTIERUNGS- D-8221 Darbau		AZ	
Oberflächen		Ra in µm	
ISO 1502		ISO 1502	
Abmessung		Schweißnaht	
ISO 1502-BF		ISO 1502-BF	

Vertraulich, alle Rechte vorbehalten ISO 16016
 Weitergabe sowie Vervielfältigung dieses Dokuments, Verwertung und Mitteilung seines Inhalts sind
 verboten, soweit nicht ausdrücklich gestattet. Zuwiderhandlungen verpflichten zu Schadenersatz.
 Alle Rechte für den Fall der Patent-, Gebrauchsmuster- oder Geschmackschutzrechte vorbehalten.