



Operating Instructions

Safety Module Combination KB55S/SS-EB75GS

EU-SG 374/EU-SG 735 / EU-SG 289

General

Safety Module ↓ ↑

Progressive safety gear - upward/downward acting = payload + weight of lift car in FREE fall

Braking device = 1/2 payload + masses UPWARDS upon tripping the overspeed governor incl. UCM/A3

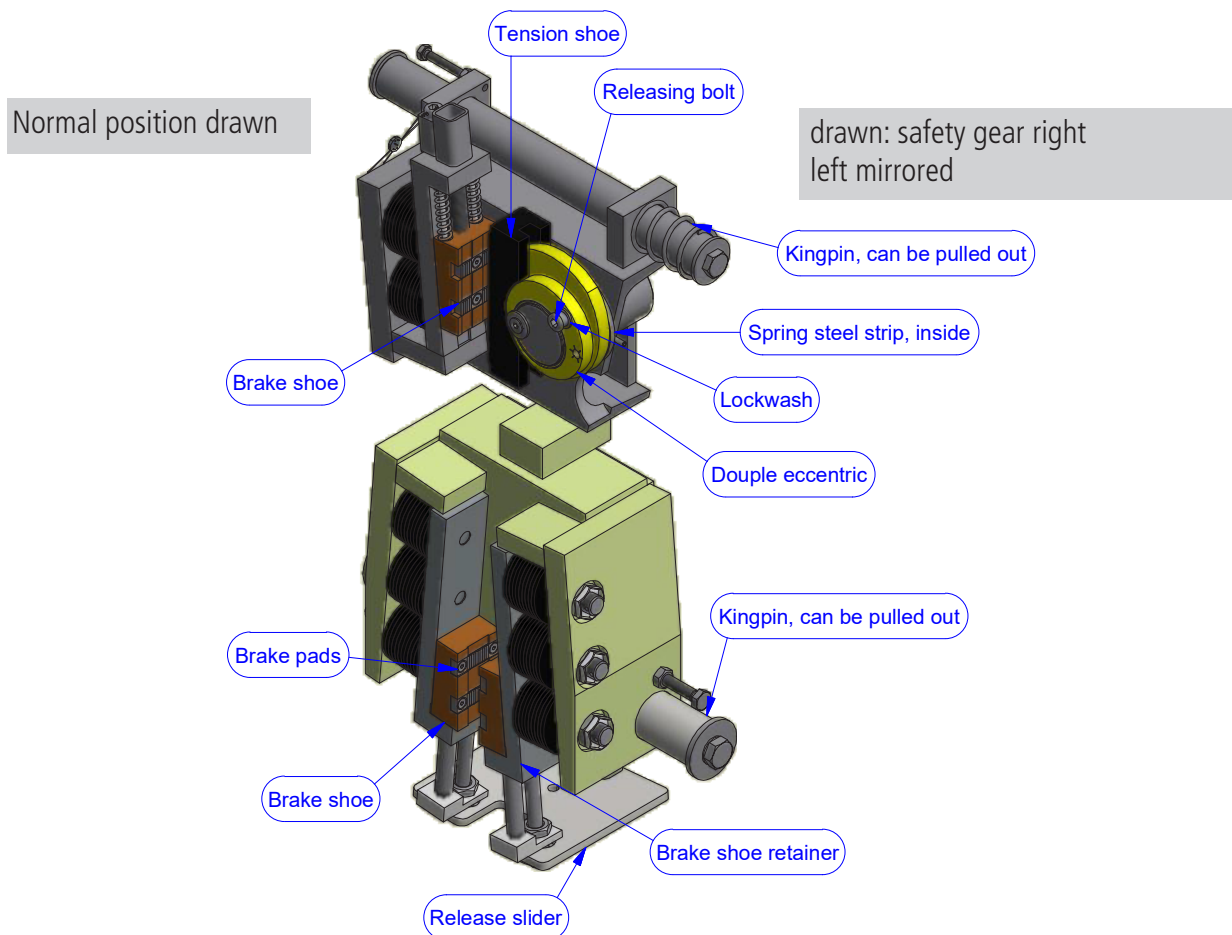

General instructions	5370.800.002
Mounting/adjustment	5370.800.003
Mounting/adjustment/check	5370.800.004
Mounting/information	5370.800.005
Check	5370.800.006
Test instructions/information	5370.800.007



Combination KB55S/SS-EB75GS

General instructions

!Important!

Prior to commissioning:

1. Before commissioning and testing the guide rails must be cleaned thoroughly prior to installation! Whether „old“ or „new“, (due to dirt, old lubricant or protective agents in case of new rails!), they must be kept clean both before and after commissioning!!!
2. Should this not take place, negative changes in the braking force etc. can/will occur: In this case, any potential claim will be rejected.
3. Should „old“ guide rails show very long skid marks or many and deep marks (e.g. from safety gear), they have to be replaced by new guide rails – of the same type.
4. After recommended test check (only functional test - low speed/empty lift car) a safety test (engagement test) must be carried out according to the applicable guidelines (e.g. EN 81-20/50), also for „SRMs“ (conveyors), or according to the manufacturer's specifications.
Should none of the above provisions apply, the test must be executed in the „downward“ direction at least with nominal speed and nominal load without any braking of the drive unit (e.g. keep operational brake open!), otherwise no performance record! In the event of uncertainties, please contact us - as manufacturer - immediately.
Periodical tests (engagement tests) must also be carried out at regular intervals.

5. The brake power is assessed by persons with professional expertise (e.g. inspection bodies etc.).



Dirt! This is not acceptable!

!Maintenance!

1. It must be possible to turn the actuating shaft manually until the gripping eccentric engages and the safety gear switch must be actuated. When pulled out from the braking position, the actuating shaft (gripping eccentric) must turn back into neutral position.
2. The guide rails must only be oiled with specified lubricants. (Observe EC-type examination certificate). No greases, oils which become resinous etc.
3. Maintenance at least once annually (or operating hours or contamination).
4. Avoid rust by cleaning and lubricating the moving parts.

Lubricate between eccentric and spring steel strip

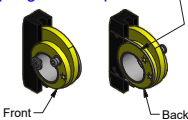

Lubricate all joints, in particular the spring and the gripping eccentric (if they are not moving smoothly).

5. It must be possible to move the safety gear/safety module smoothly on the kingpin (floating system).
6. Check the tractive force of the overspeed governor with required tractive force of the safety gear/safety module (at least statically).

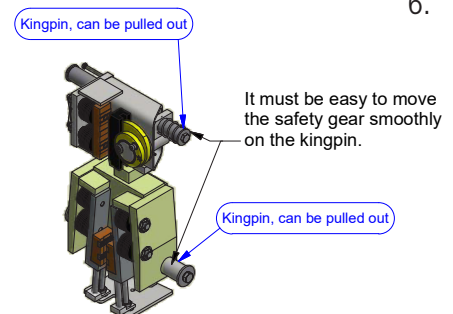

6.

Combination KB55S/SS-EB75GS

Mounting / Adjustment

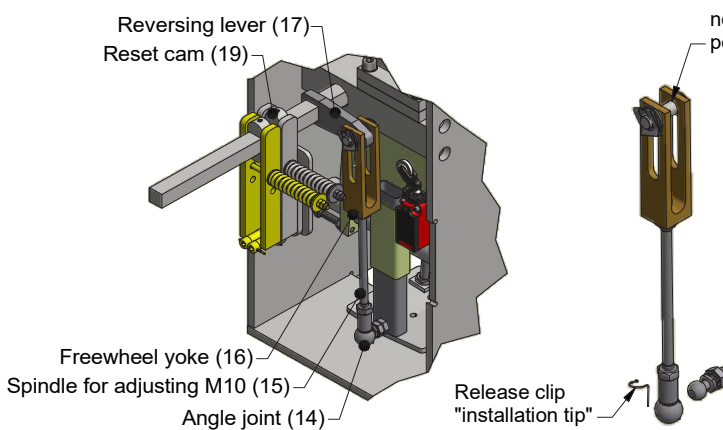
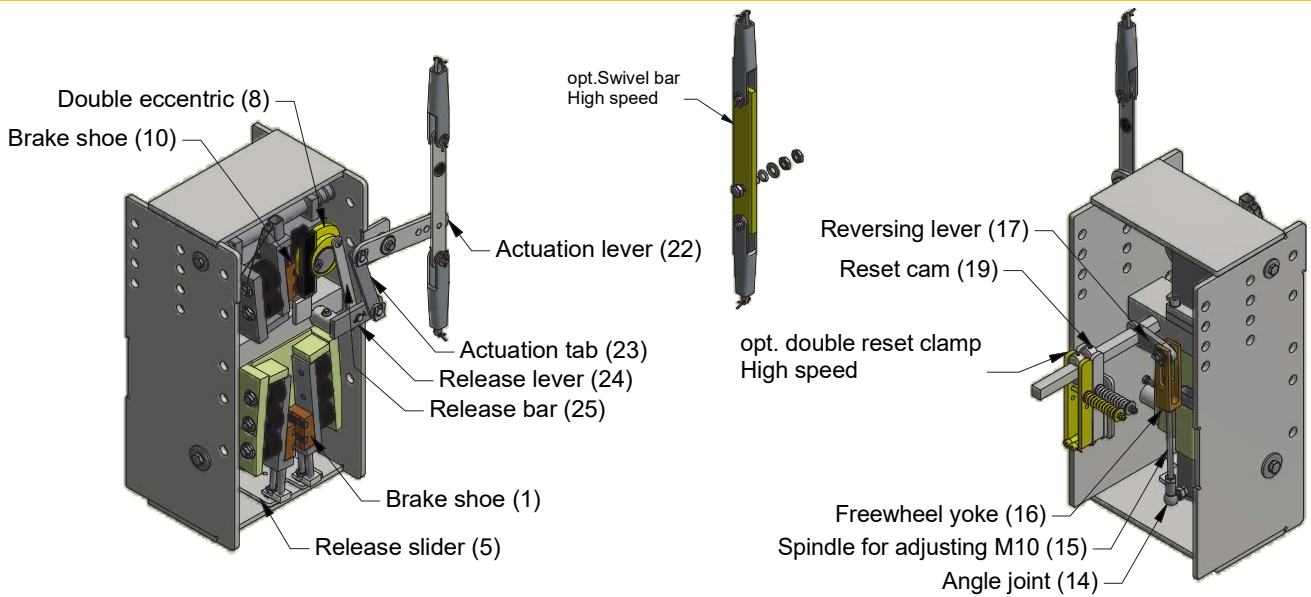

no backlash in neutral position of brake wedges

Setting type: KB 55S/SS - working downwards

1. Adjust and set connection between the reversing lever (17) and the release slider (5) with free-wheel yoke (16) and spindle for adjusting (15), angle joint (14).

Adjustment:

Turn the thread M10 (15) with the angle joint (14) until the length to the release slider (5) is adjusted in the open position (both sides)

Safety gear KB 55S/SS Adjustment of the set screws (M8) **Attention!**

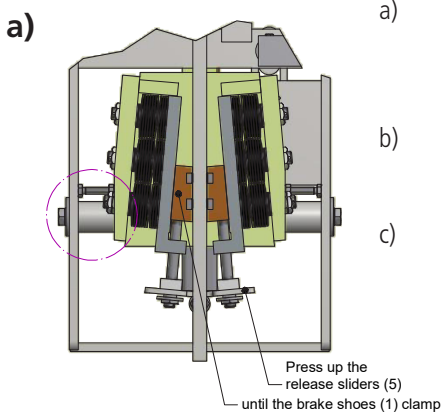

- a) Press the release slider (5) up until the brake shoes (1) are clamped on the guide rail (centering the safety gear on the guide rail)
- b) Then lock the set screws with approx. 0.5 - 1.0 mm clearance (the bolt heads **must never be** resting on the external housing)
- c) release either by hand or by briefly lifting the brake shoes (1)

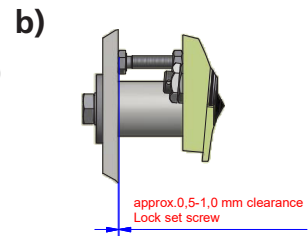



Combination KB55S/SS-EB75GS

Mounting / Adjustment / Check

Setting type: EB 75 GS - acting upwards

1. Adjust the braking device and guide rail using the adjusting screw (M6) until a clearance of 1 - 2 mm between the brake shoe (10) and the rail is set, then lock.
2. Mount the release bar (25) with lockwasher on double eccentric (8) to the **top** borehole (thread M8) using the releasing bolt (M8)

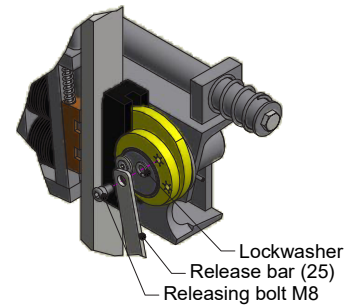
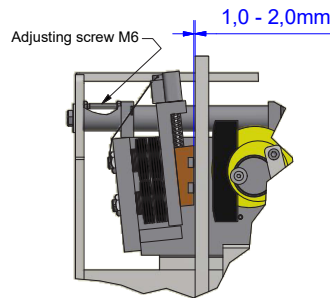
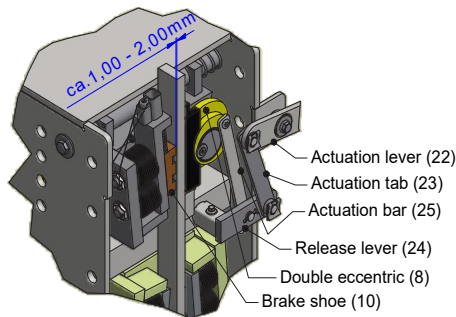

Front view

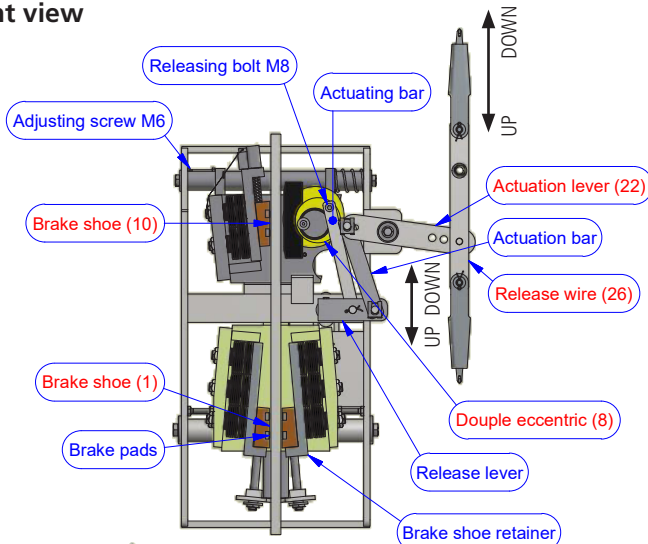

Mounting / adjustment / check

1. Setting type KB 55S/SS to synchronous running
 ↑ Push up (engagement downwards) the actuation lever (22) until the brake shoes (1) clamp on the guide rail (press).

Check:

The brake shoes (1) must clamp (press) in both safety gears. If not, the spindles (15) must be adjusted (some lead of the brake shoes (1) opposite the Actuation lever (22) is an advantage!)

2. Check type EB 75 GS for synchronous running
 ↓ Press down (brake upwards) the actuating lever (22) until both double eccentrics (8) are pressed onto the guide rails.
 Check: If not: Change clearance 1-2 mm between brake shoe (10) and guide rail slightly by adjusting the adjusting screw (M6).

Back view

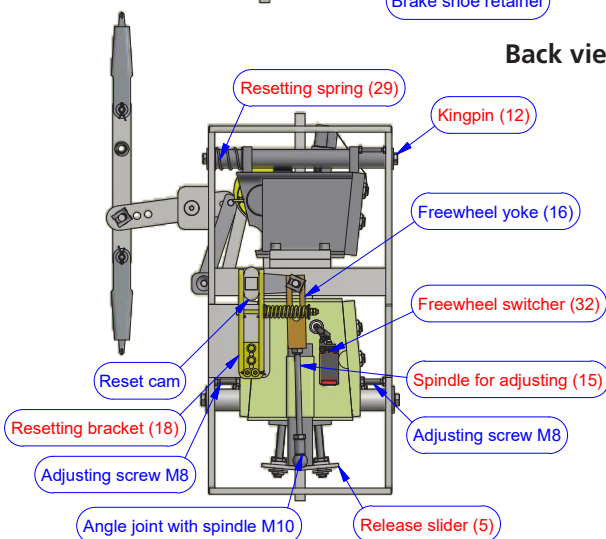

Note: A test run provides clarity! Slow raising of the system (test run) with activation of the actuation lever (22) until the double eccentrics (8) turn in automatically. Stop the system immediately when the double eccentrics turn in!

Then check that both double eccentrics (8) have clamped. Lower the system to release! Both brake mechanisms must reset automatically via the reset spring (29) and the kingpin (12)!

3. Attachment of the release cable coupling (26) – „Long side“ up!
4. Adjusting the reset clamping spring (18). Select the pre-tension to ensure normal operation. Observe the pull-in forces of the release components, e.g. overspeed governor! (The pull-in force must be double that of the safety module at the overspeed governor!)

Combination KB55S/SS-EB75GS

Mounting / Information



Back view
of opposite

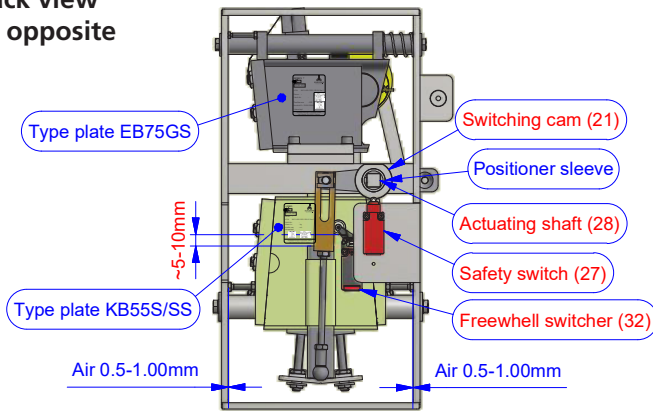

Adjustment and setting of the safety switch (27)

Position the safety switch in such a way with respect to the switching cam (21) that slight vertical movements of the actuating shaft (28) do not cause the system to switch, but only when the release shaft turns!

Note: Make sure that the free wheel switcher (32) switch **before** the brake shoe (1) is clamped/pressed onto the guide rail!

Tip: Gap between the switching part and release slider (5) approx. 5 – 10 mm!

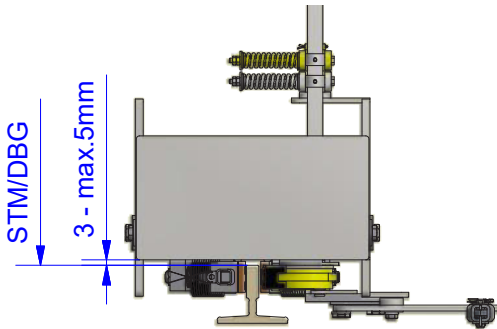

Make sure that the immersion depth of the rail is correct.

- 3 - max. 5mm

The safety module ↓ ↑ may only be installed if the values indicated on the type plate correspond to the lift data. Check that the lead sealing is undamaged.

Attention: Strictly avoid any contact with the guide rail in case of spring-loaded guiding elements! (Observe spring deflections!, otherwise unintended engagement etc!)

Note: For larger lifts!/loads etc. (forklift operation!) make sure that the guide rails and the load-bearing components are stable. Safety gears etc. must not be pressed onto the guide rail by loading activity or one-sided loading of the lift! This is because the later enlargement of the clearance is often not possible.

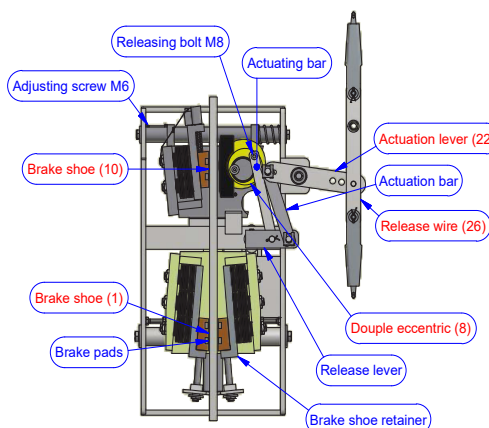

↓ KB55S	
EU-SG 374	
Date: -	
UCM: NL12-400-1002-169-02 Rev.1	
Serial-Nu.: -	
Weight ↓ =: - kg	
Tripping spd. max.: - m/s	
Guide head: -	
	Oil Ja / Yes
Aufzugstechnologie G.Schlosser GmbH Felix-Wankel-Str.4, 85221 Dachau	

EB75GS ↑	
EU-SG 289	
UCM: NL12-400-1002-169-05 Rev.1	
Date: -	
Serial-Nu.: -	
Tripping spd. max.: - m/s	
Brake force ↑ = 43800-49999N	
Guide head: -	
	Oil Ja / Yes
Aufzugstechnologie G.Schlosser GmbH Felix-Wankel-Str.4, 85221 Dachau	



Combination KB55S/SS-EB75GS

Check

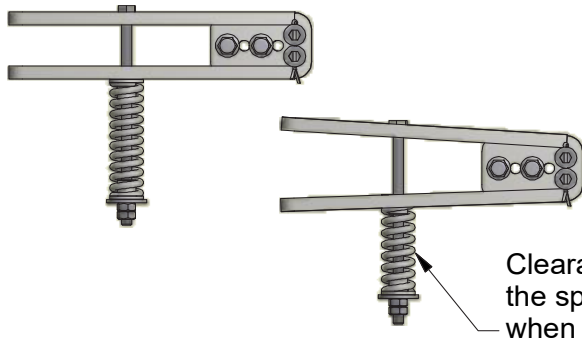

Attention:

Adjust the resetting spring in such a way that the pull-in forces are not too high and to ensure sufficient spring deflections.

Test in detail

DOWNWARDS:

- 1,25 times nominal load and nominal speed
- or nominal load and with tripping speed
- Keep brake open!

Note:

To make it easier to draw the car out of the engagement, it is recommended to carry out the test near a door so that the load from the car can be discharged there.

UPWARDS:

- Empty car with min. nominal speed without any braking aid (operational brake open, drive system switched off)

After the test, make sure that no damage has occurred that could impair the normal operation of the lift. If necessary, brake shoes can be replaced. Visual examination is considered sufficient.

The objective of the test prior to commissioning is to determine the proper assembly, the correct adjustment and the strength of the functional unit, comprising the car - safety gear - guide rails - rail mountings.

Tripping/engagement forces:

At least double the **required** pull-in force ↓ ↑ of the safety gear/safety module **but** at least 300N in both directions ↓ ↑.

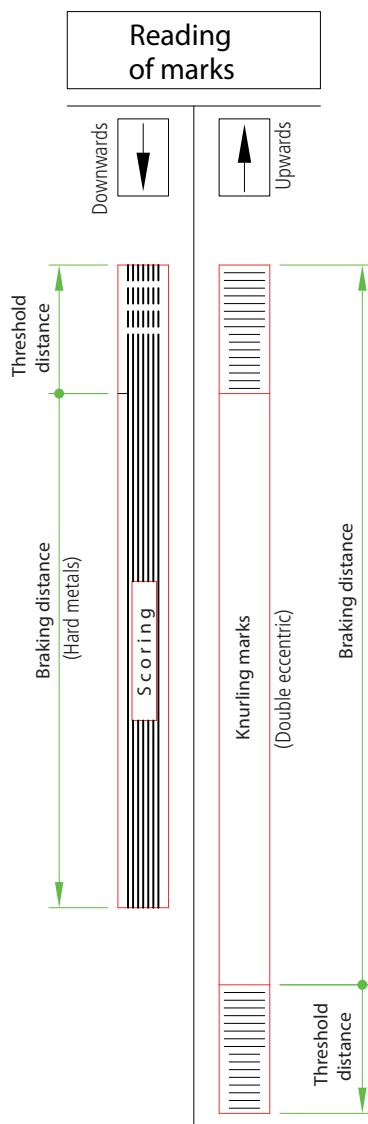

Combination KB55S/SS-EB75GS

Test instructions / information



Pulling out of the ↓ engagement ↑ brake position.

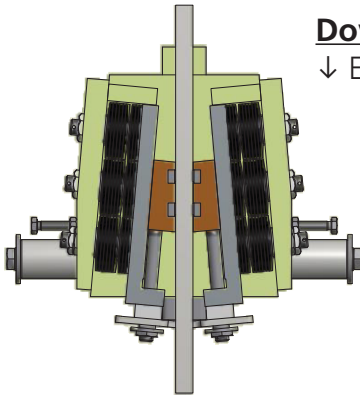

Downwards

↓ Engagement position: the brake shoes are pulled in upwards!
Pull off the ↓ engagement position in steps:

- Start quickly in upward direction using the re-levelling control.
- Several repetitions = in principle: loosen and tighten ropes
- Handwheel aid
- Empty the car
- Traction sheave clamp, lifting etc.

Upwards

↑ Brake position: The M8 bore hole of the double eccentric shows approx. 11 o'clock.
Pull off the ↑ brake position in steps:

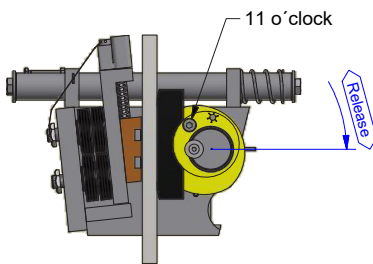

- Start quickly in downward position using the re-levelling control.
- Several repetitions = in principle: loosen and tighten ropes.
- Handwheel aid
- Load the car
- Traction sheave clamp, car hanging freely etc.

Note:

1. In the case of weightless testing downwards (electronic test device), the bouncing of the cabin can cause the brake to fall back or be pulled into the upwards braking position! (Bouncing counterweight!).
2. Also, a release from the upwards braking position can cause the brake to fall back or be pulled into the downwards direction! (Jerky release from above!).

Note:

The release of the cabin from the downwards braking position tends to be more difficult, the „lighter“ the cabin is in relation to the nominal load. (Heavy counterweight to light cabin!).

Liability and guarantee:

The company Aufzugtechnologie Schlosser does **not** accept any liability or provide any guarantee for damages resulting from incorrect handling or inappropriate use of our products contrary to these instructions.

Assembly of actuating gear KB55S/SS-EB75GS

